

## Thermodynamics FE Review

### A. Topics

#### Morning Session Topics

1<sup>st</sup> and 2<sup>nd</sup> Laws  
Energy, Heat and Work  
Availability and Reversibility  
Cycles  
Ideal Gases  
Mixture of Gases  
Phase Changes  
Heat Transfer  
Enthalpy, Entropy

#### Afternoon Session Topics

Ideal and Real Gases  
Reversibility, Irreversibility  
Thermodynamic Equilibrium  
Psychometrics  
Performance of Components  
Cycles and Processes  
Combustion  
Energy Storage  
Cogen, Regen, Reheat

### B. Know your Handbook

General Section Thermodynamics: Pages 73- 83

- Properties
  - Steam Tables SI only
  - R-134a P-h diagram
  - Gas properties, both units
- Ideal Gas Relationships
  - Boundary work (closed systems)
  - Isentropic relations
  - Gas mixtures
- First Law
  - Closed system
  - Open systems
- Steady flow devices
- Cycles
  - Carnot
  - Rankine
  - Otto
  - Refrigeration
- Phase Relations
- Combustion
- Psychometric Chart

- Second Law
  - Entropy
  - Increase in entropy principle
  - Irreversibility
  - Availability, exergy

Mechanical Engineering Section Thermodynamics: Pages 231 - 248

- HVAC
- Diesel cycle
- Brayton cycle
- Feedwater heaters, mixers
- Pumps, turbines and compressors
- Two-stage refrigeration

### C. Properties

Specific Volume

Internal Energy

Enthalpy

Entropy

### Water: Steam Tables

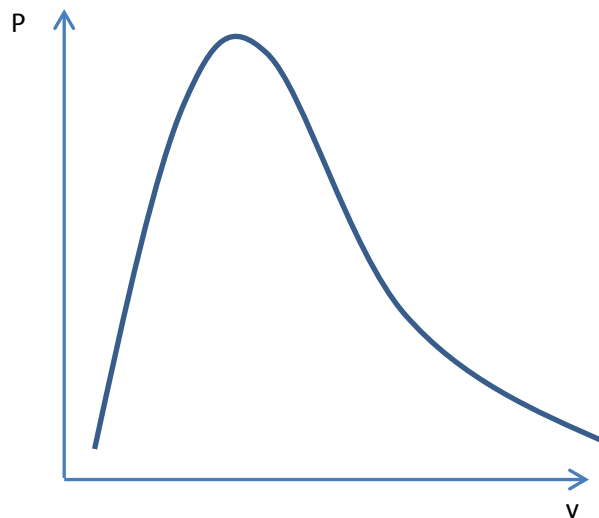

Quality

How do I know if I am on the Saturated or Superheated tables?

How do I determine the properties of a compressed liquid?

Example 1: Water at a temperature of 140 °C has a specific volume of 0.30. Its quality is closest to:

- a) 0.36      b) 0.41      c) 0.62      d) 0.83

Example 2: Water at a pressure of 100 kPa has a specific volume of 2.45 m<sup>3</sup>/kg. Its enthalpy in kJ/kg is closest to:

- a) 2600      b) 3000      c) 3400      d) 4000

### Refrigerant (R 134 a)

Pressure-Enthalpy Diagram

Example 3: R-134a at a pressure of 200 kPa has a specific volume of 0.15 m<sup>3</sup>/kg. Its enthalpy in kJ/kg is closest to:

- a) 490      b) 510      c) 530      d) 550

Example 4: R-134a at a pressure of 200 kPa has a enthalpy of 350 kJ/kg. Its quality is closest to:

- a) 0.75      b) 0.80      c) 0.85      d) 0.90

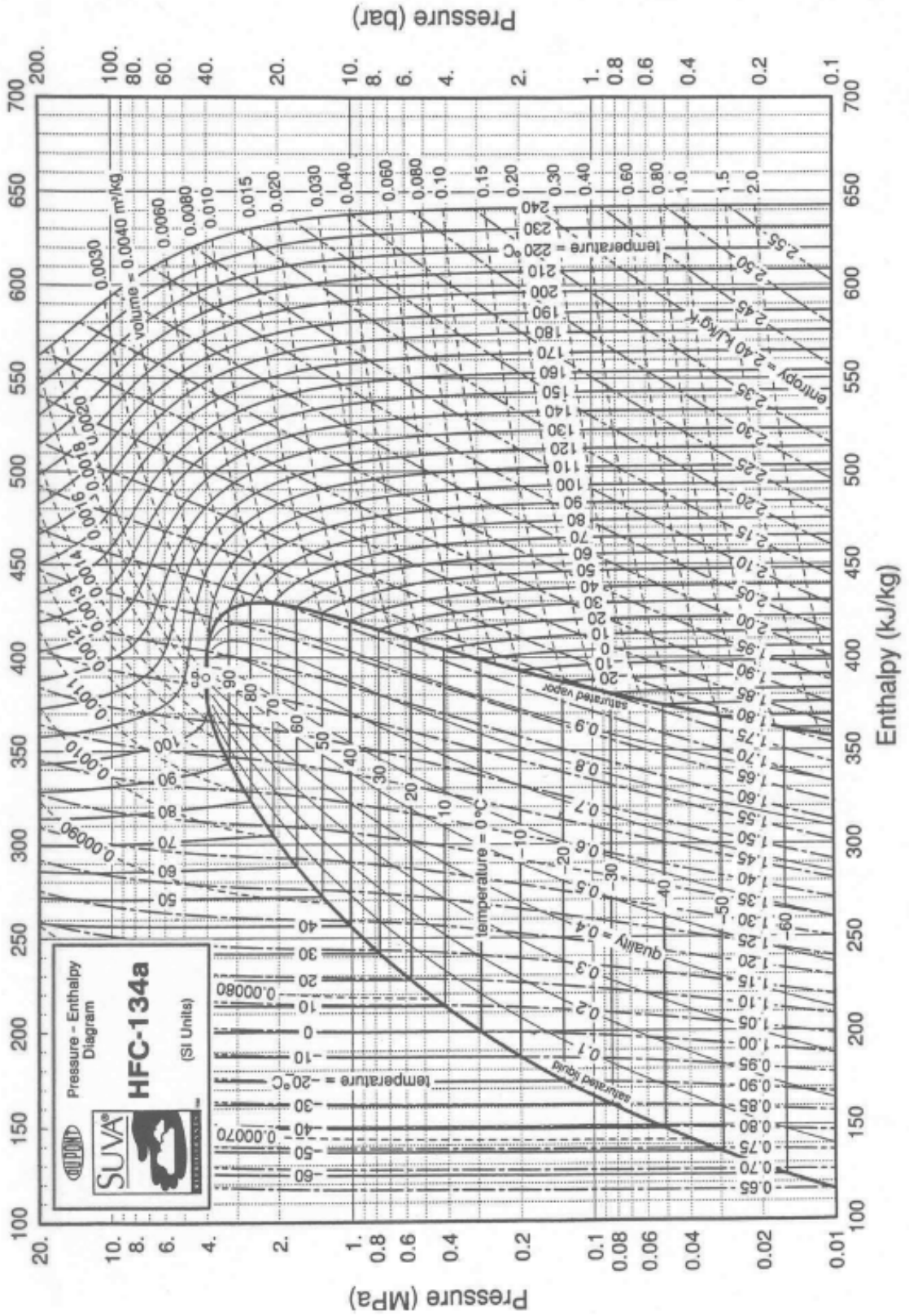

## Ideal Gas

Ideal Gas Assumptions

Ideal Gas Equation of State

Ideal Gas Internal Energy

Ideal Gas Enthalpy

Ideal Gas Entropy

Example 5: Carbon dioxide is heated from 80 °F to 200 °F at a constant pressure. The change in internal energy in BTU/lb<sub>m</sub> is closest to:

- a) 101      b) 24      c) 79      d) 19

Example 6: A rigid container containing 2.0 kg of air is heated from an initial temperature of 20 °C and pressure of 100 kPa until the final pressure is 1.0 MPa. The change in entropy in kJ/kgK is closest to:

- a) 1.1      b) 0.8      c) 4.6      d) 3.4

## Ideal Gas Isentropic Relationships

Example 7: Air is heated in an isentropic process from an initial temperature of 80 °F and pressure of 15 psia to a final pressure of 300 psia. The final temperature in °F is closest to:

- a) 810      b) 190      c) 1270      d) 650

### D. First Law of Thermodynamics, Closed Systems

#### Boundary Work

#### Ideal Gas Boundary Work

Example 8: A fixed mass of Air is heated in an isentropic process from an initial temperature of 80 °F and pressure of 15 psia to a final pressure of 300 psia. The work (BTU/hr) done on the air during this process is closest to:

- a) -128      b) 128      c) 8      d) -8

Example 9: Steam is expanded in a piston-cylinder at a constant pressure from a saturated liquid at  $T = 210\text{ }^{\circ}\text{C}$  to a saturated vapor at  $T = 210\text{ }^{\circ}\text{C}$ . The work (kJ/kg) done by the steam during this process is closest to:

- a) 400      b) 1900      c) 1700      d) 200

Example 10: Steam is expanded in a piston-cylinder at a constant pressure from a saturated liquid at  $T = 210\text{ }^{\circ}\text{C}$  to a saturated vapor at  $T = 210\text{ }^{\circ}\text{C}$ . The heat transfer (kJ/kg) to the steam during this process is closest to:

- a) 400      b) 1900      c) 1700      d) 200

Example 11: One kg of liquid water is heated from  $15\text{ }^{\circ}\text{C}$  to  $90\text{ }^{\circ}\text{C}$  in a small coffee pot containing a 500 W heater. Assuming the heat capacity of the water is  $4.18\text{ kJ/kgK}$ , the time to heat the water in minutes is closest to:

- a) < 1      b) 6.3      c) 10.5      d) 32.1

Example 12: Air at 300 K is expanded in an isothermal process from an initial volume of  $2\text{ m}^3$  to a final volume of  $4\text{ m}^3$ . The amount of heat transferred to the air (kJ/kg) is closest to:

- a) -60      b) -30      c) 0      d) 60

## E. First Law of Thermodynamics Open Systems

### Typical System Components

Nozzles

Throttles

Pumps and Compressors

Turbines

Heat Exchangers and Mixers

Example 13: Refrigerant (R134 a) undergoes a throttling process from a saturated liquid at 1.0 MPa to a pressure of 200 kPa. The quality of the throttled refrigerant is closest to

- a) 0      b) 15      c) 25      d) 35



Example 14: Argon flows through a nozzle with an inlet pressure of 1 MPa, temperature is 20 °C and velocity of 10 m/s. The outlet pressure is 100 kPa and the velocity is 100 m/s. The temperature (°C) of the Argon at the exit of the nozzle is closest to:

- a) 4            b) 10            c) 24            d) 36

Example 15: The steady state mixing tank shown below is being used to condense steam returning from a distillation process. The maximum steam mass flow rate (kg/s) allowed that will result in not exceeding the permitted outlet temperature is closest to:

- a) .25            b) 1.1            c) 2.2            d) 4

$\dot{m} = 2.2 \text{ kg/s}$   
 $T = 20 \text{ }^\circ\text{C}$   
 $P = 125 \text{ kPa}$

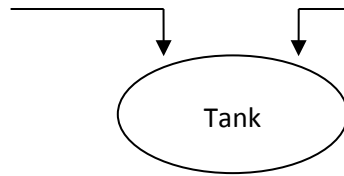

$\dot{m} = ?$   
 $T = 200 \text{ }^\circ\text{C}$   
 $x = 0.6$

$P = 125 \text{ kPa}$   
 $T_{\text{permitted}} = 65 \text{ }^\circ\text{C}$

#### F. First Law Applied to Cycles

An ideal Rankine cycle is shown in the diagram below. Water is the working fluid and the properties of each state are shown below. Use this to work Examples 16-20.

Location	Properties
1	$T = 45\text{ }^{\circ}\text{C}$ , saturated liquid
1-2	Specific pump work = $1.0\text{ kJ/kg}$
2	$P = 1.0\text{ MPa}$
3	$T = 350\text{ }^{\circ}\text{C}$ , $P = 1.0\text{ MPa}$
4	$T = 45\text{ }^{\circ}\text{C}$ , $x = 0.9$

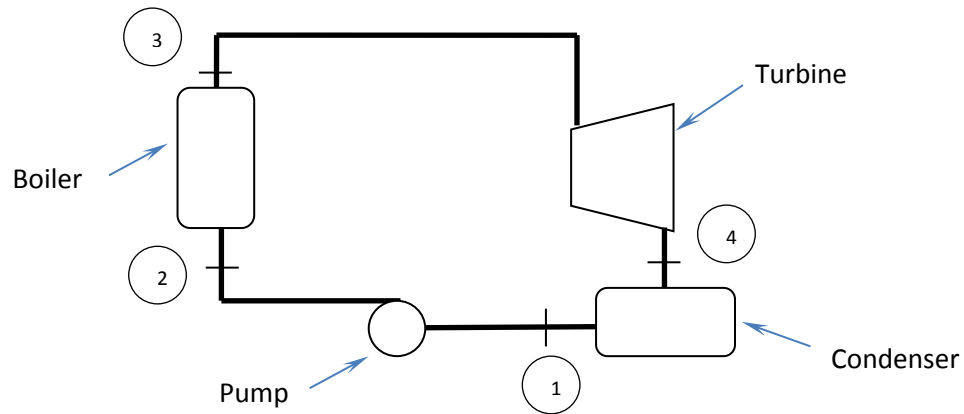

Example 16: The specific work (kJ/kg) out of the turbine is closest to:

- a) 800      b) 1600      c) 2200      d) 3000

Example 17: The specific heat transfer (kJ/kg) into the boiler is closest to:

- a) 800      b) 1600      c) 2200      d) 3000

Example 18: The specific heat transfer (kJ/kg) out of the condenser is closest to:

- a) 800      b) 1600      c) 2200      d) 3000

Example 19: The cycle thermal efficiency (%) is closest to:

- a) 25      b) 35      c) 45      d) 55

Example 20: The mass flow rate (kg/s) required for a power output of 50 MW is closest to:

- a) .017      b) 17      c) .060      d) 60

## G. Second Law of Thermodynamics

Ramifications

Carnot Heat Engines

Example 21: A Carnot Heat Engine operates with a source temperature of 1500 °C and a sink temperature of 150 °C. The thermal efficiency (%) of this heat engine is closest to:

- a) 90      b) 75      c) 25      d) 10

Example 22: A Carnot Heat Engine operates with a source temperature of 1200 °F and a sink temperature of 80 °F. The cycle rejects 1000 BTU/s to the low temperature sink. The net work done by this cycle is closest to:

- a) 14000      b) 15000      c) 2000      d) 3000

## Entropy

### Isentropic Efficiency

Example 23: Steam enters a turbine at a pressure of 1 MPa and a temperature of 350 °C. The steam exits into a condenser at a temperature of 70 °C. The isentropic efficiency of the turbine is 90%. The quality (%) of the steam exiting the turbine is closest to:

- a) 90      b) 93      c) 96      d) 99

Example 24: Steam enters a turbine at a pressure of 1 MPa and a temperature of 350 °C. The steam exits into a condenser at a temperature of 70 °C. The isentropic efficiency of the turbine is 90%. The specific work (kJ/kg) of the turbine is closest to:

- a) 500      b) 700      c) 800      d) 600

### Entropy Generation

Example 25: Air is expanded in a constant pressure process at 200 kPa from an initial temperature of 100 °C to a final temperature of 200 °C while adding heat from a heat source at a temperature of 500 °C. The entropy (kJ/kgK) generated during this process is closest to:

- a) 0.11      b) 0.23      c) 0.56      d) 0.69

Example 26: Steam enters an adiabatic turbine at a pressure of 1 MPa and a temperature of 350 °C at a rate of 10 kg/s. The steam exits into a condenser as a saturated vapor at a temperature of 70 °C. The entropy generation rate (kW/K) of the turbine is closest to:

- a) - 4.5      b) -7.5      c) 4.5      d) 7.5

H. Cycle Analysis

Rankine Cycle

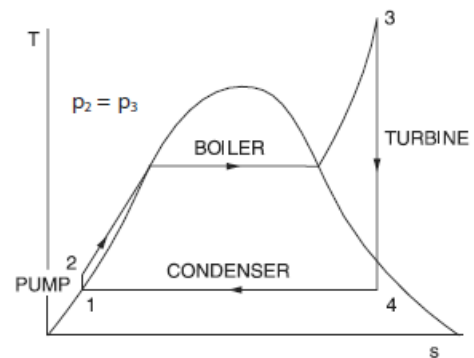
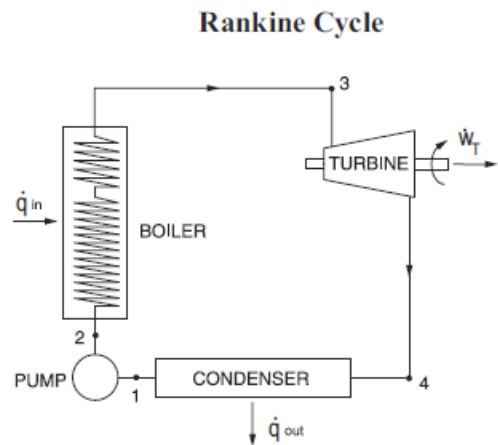

$$\eta = \frac{(h_3 - h_4) - (h_2 - h_1)}{h_3 - h_2}$$

Example 27: A Rankine cycle operates with a thermal efficiency of 40%. If the net power from the cycle is 50 MW, the heat rejection rate in the boiler (MW) is closest to:

- a) 125      b) 100      c) 75      d) 50

Refrigeration Cycle

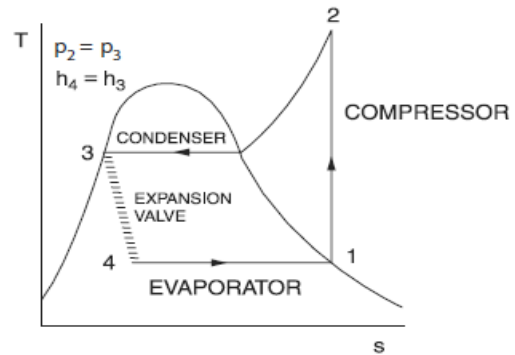
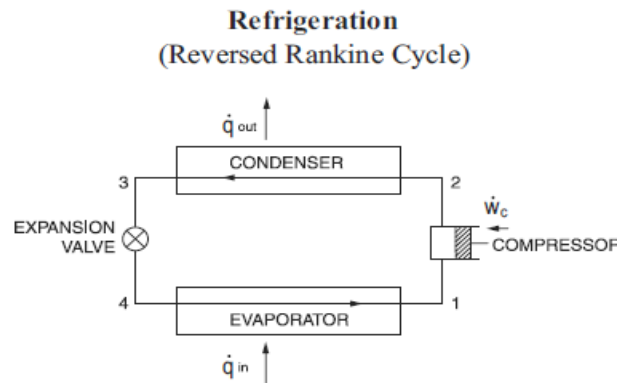

$$\text{COP}_{\text{ref}} = \frac{h_1 - h_4}{h_2 - h_1} \qquad \text{COP}_{\text{HP}} = \frac{h_2 - h_3}{h_2 - h_1}$$

Example 28: An ideal refrigeration cycle using R134a operates between pressure of 2 MPa and 300 KPa. The cooling capacity (kJ/kg) of this cycle is closest to:

- a) 25      b) 50      c) 75      d) 100

Example 29: An ideal refrigeration cycle using R134a operates between pressure of 2 MPa and 100 KPa. The COP of this refrigerator is closest to:

- a) 1.5      b) 2.0      c) 2.5      d) 3.0

Example 30: An ideal heat pump using R134a operates between pressure of 2 MPa and 300 KPa. The heating capacity (kJ/kg) of this cycle is closest to:

- a) 140      b) 100      c) 80      d) 40

Otto Cycle

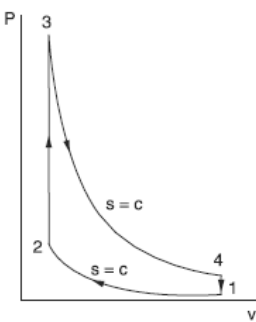

**Otto Cycle**  
(Gasoline Engine)

$$\eta = 1 - r^{1-k}$$

$$r = v_1/v_2$$

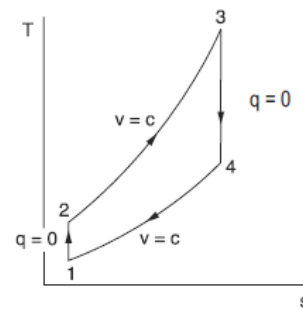

Example 31: An Otto Cycle with a compression ratio of 8:1 has an intake temperature of 80 °F. The specific work (BTU/lb<sub>m</sub>) of compression is closest to:

- a) 20      b) 60      c) 120      d) 170

Example 32: An Otto Cycle with a compression ratio of 8:1 has an intake temperature of 80 °F. The cycle operates with a heat input of 10000 BTU/hr. The net power output (BTU/hr) from the cycle is closest to:

- a) 4000      b) 4500      c) 5000      d) 5500

Example 33: An Otto Cycle with a compression ratio of 8:1 has an intake temperature of 80 °F. The cycle operates with a heat input of 100 BTU/lb<sub>m</sub>. The highest temperature (°F) in the cycle is:

- a) 1500      b) 1700      c) 1900      d) 2100

## Diesel Cycle

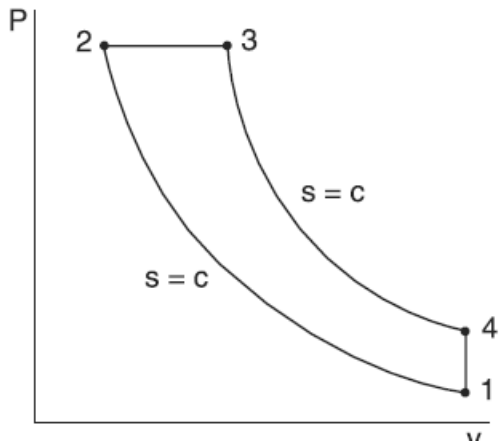

$$r = V_1/V_2$$

$$r_c = V_3/V_2$$

$$\eta = 1 - \frac{1}{r^{k-1}} \left[ \frac{r_c^k - 1}{k(r_c - 1)} \right]$$

$$k = c_p/c_v$$

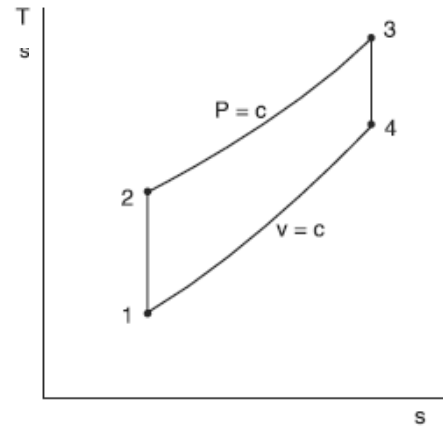

Example 34: A Diesel Cycle with a compression ratio of 24:1 and a cutoff ratio of 1.5:1. The temperature at the end of the compression stroke is measured to 1400 °C. The temperature (°C) at the end of the combustion process is closest to:

- a) 2250      b) 2200      c) 2150      d) 2100

Example 35: A Diesel Cycle with a compression ratio of 24:1 and a cutoff ratio of 1.5:1. The temperature at the end of the compression stroke is measured to 1400 °C. The heat added during the combustion process is closest to:

- a) 200      b) 850      c) 700      d) 150

Example 36: A Diesel Cycle with a compression ratio of 18:1 and a cutoff ratio of 1.5:1. The intake temperature is 20 °C, the temperature at the end of the compression stroke is 658 °C, the temperature at the end of the combustion process is 1123 °C, and the exhaust temperature is 244 °C. The net work (kJ/kg) from this cycle is closest to:

- a) 200      b) 300      c) 400      d) 500



## Brayton Cycle

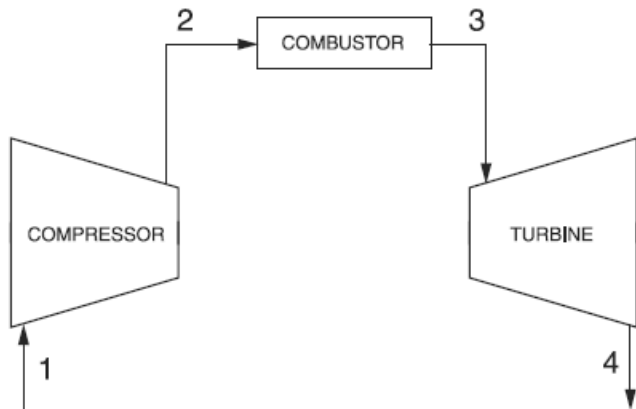

$$w_{12} = h_1 - h_2 = c_p(T_1 - T_2)$$

$$w_{34} = h_3 - h_4 = c_p(T_3 - T_4)$$

$$w_{\text{net}} = w_{12} + w_{34}$$

$$q_{23} = h_3 - h_2 = c_p(T_3 - T_2)$$

$$q_{41} = h_1 - h_4 = c_p(T_1 - T_4)$$

$$q_{\text{net}} = q_{23} + q_{41}$$

$$\eta = w_{\text{net}}/q_{23}$$

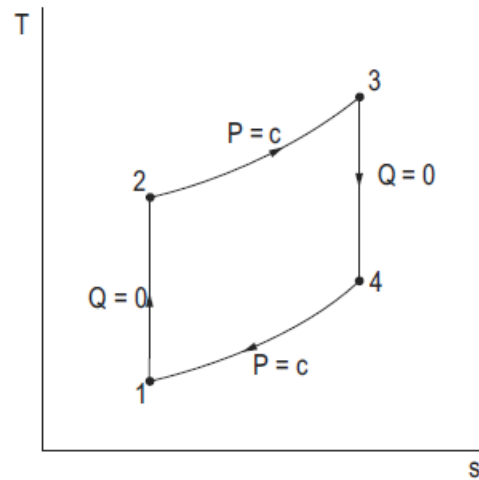
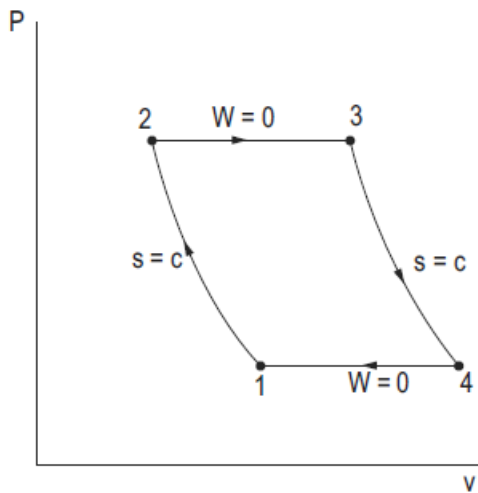

Example 37: An ideal gas turbine operates on an Air Standard Cycle between 100 kPa and 600 kPa. The inlet temperature is 20 °C and the temperature of the gas exiting the combustion process is 600 °C. The heat added during combustion (kJ/kg) is closest to:

- a) 580      b) 380      c) 410      d) 280

Example 38: An ideal gas turbine operates on an Air Standard Cycle between 100 kPa and 600 kPa. The inlet temperature is 20 °C and the temperature of the gas exiting the combustion process is 600 °C. The thermal efficiency of this cycle is closest to:

- a) 0.4      b) 0.5      c) 0.3      d) 0.6